

Product guide

Kell Systems ComputerVault Pro

Features, specifications and performance data

Product evolution: v7.8
Issue date: 1st November 2008

Table of contents

Section 1: Standard features and general specifications

Page	2	Model PSE12
	5	Model PSE18
	8	Model PSE24
	11	Model PSE38

Section 2: Noise reduction

14	ComputerVault Pro noise reduction performance and simple relative noise reference criteria
----	--

Section 3: Thermal considerations

15	Thermal performance of Kell Systems ComputerVault Pro
16	Example of server CPU operating temperatures within a ComputerVault Pro

Section 4: Dimensioned drawings and ComputerVault Pro layouts

17	External views - all ComputerVault Pro
18	Side sections - all ComputerVault Pro
19	Detailed plan section - common to all ComputerVault Pro

Section 5: Notes for installers

20	Kell Systems ComputerVault Pro rack planning guidelines
----	---

Section 6: About Kell Systems

21	Kell Systems locations and contact details
----	--

Standard Features and General Specifications

Model PSE12

Air-cooled acoustic server rack enclosure v7.8

PSE12 page 1 of 3

Kell Systems ComputerVault Pro enable deployment of servers and network hardware directly in the office workspace, doing away with the need for dedicated computer rooms. They combine extreme noise reduction and very high thermal capacity with exceptional reliability and a truly all-inclusive, plug-and-play specification. A host of unique, installer-friendly features ensure quick and easy systems deployment and their office-quality appearance blends seamlessly into almost any office environment.

Physical capacity:	12 rack spaces
Noise reduction:	18.5 dB
Max. recommended thermal load:	1.2 kW (4,100 BTU / hr)
Integrated power distribution:	7 x surge-protected outlets
Power consumption:	19 Watts

Please note that standard Kell Systems ComputerVault Pro as shown herein are not suitable for use with blade servers. Please contact your Kell representative about alternative Kell solutions for deployment of these types of devices.

Pictured here in Kell Systems Light Oak effect laminate finish. A wide range of laminate and real wood finishes are available.

Kell laminate-finish ComputerVault Pro have doors and tops that are easy for the user to interchange, so if a unit needs to be relocated to a different office, the look of the cabinet can easily be updated.



Kell Systems Model PSE12 air-cooled acoustic server rack enclosure v7.8

Please note: international product code suffixes are UK, EU (Europe), US (United States & Canada) or CS (custom)

PSE12 page 2 of 3

Standard Features and General Specifications

External dimensions:	Height 750 mm / 29.5" x Width 750 mm / 29.5" x Depth 1130 mm / 44.5"
Weight:	119 kg / 262 lbs
Physical rack capacity:	12 x EIA 1 $\frac{3}{4}$ " / 44.5 mm rack spaces 4-post rack, fully EIA-compliant, with fixed rear posts and adjustable front posts Rack depth 800 mm / 31.5", adjustable down to 720 mm / 28.3" <i>(option for baying kit to link cabinets together, part code BK12)</i>
Extra internal cabinet depth:	Forward of the front rack posts: 100 mm / 4" space for front frame cabling/patching <i>(see product guide page 19, figure "Kell Systems ComputerVault Pro plan section")</i> Rearward of the rear rack posts: 60 mm / 2" except where fan modules intrude <i>(see product guide page 18, figure "Kell Systems ComputerVault Pro side sections")</i>
Floor space requirements:	Individual cabinets are designed to be pushed back flush against a wall. An air space of 200 mm / 8" on both sides of the cabinet is essential for normal operation.
Baying cabinets together:	Baying kit option available. The easy-to-fit baying kit maintains the soundproof seal but opens adjacent cabinets onto each other internally. Special notes on baying: 1: Unlike single cabinets, bayed cabinets cannot be pushed fully back against a wall. Air space of 100 mm / 6" behind the cabinet is essential for normal operation. 2: Baying PSE12 cabinets together reduces the maximum recommended thermal load in each cabinet from 1.2 kW to 1 kW. 3: In bayed cabinets, it is essential that the thermal load is distributed evenly between the cabinets.
Cooling system:	1 x Kell Systems ultra-low-noise exhaust fan module 1.2 kW maximum recommended total thermal load (or 4,100 BTU / hr)
Power consumption:	19 Watts total power consumption by the PSE12 itself, including cooling system
Noise of PSE12 itself:	40.5 dBA total noise generated by unit, measured 1.0 m / 39" in front of the cabinet
Noise reduction:	18.5 dB broadband noise reduction, measured 1.0 m / 39" in front of the cabinet <i>(HP and Dell servers used as noise source in noise reduction measurements)</i>
Mobility:	4 x heavy duty castor-type wheels Front wheels have 360° rotation for steerability Rear wheels have fixed front-to-back motion for stability
Rear and side access:	Detachable rear side panels, left and right, for installation and maintenance access Detachable rear fan module backplane gives completely open rear rack access
Cable management:	70mm / 2.75" width full-height vertical cable trays to each side of front of rack 70mm / 2.75" width full-height vertical cable trays to each side of middle of rack 70mm / 2.75" width full-height vertical cable trays to each side of rear of rack <i>(see product guide page 19, figure "Kell Systems ComputerVault Pro plan section")</i> Option for heavy duty cable management ladders to front of rack for larger scale network cabling applications, part code VCM12
Dust filtering:	Optional air intake dust filters, part code DF12

Kell Systems Model PSE12 air-cooled acoustic server rack enclosure v7.8

Please note: international product code suffixes are UK, EU (Europe), US (United States & Canada) or CS (custom)

PSE12 page 3 of 3

Standard Features and General Specifications (continued)

Internal power distribution:	<p>All power outlets in Kell Systems PSE12 feature surge protection</p> <p>USA/Canada: 7 x US 3 pin sockets, arranged vertically</p> <p>UK & Europe: 7 x IEC 320 C13 (10 A / 220/240 V) sockets, arranged vertically</p> <p>Rest of world: 7 x IEC 320 C13, arranged vertically, unless specified otherwise</p>
Power input connection:	<p>All PSE12 have power input via an IEC 320 C14 (male) trailing lead for connection to an in-rack UPS, and an extension cable for connection to a wall outlet. User may choose the preferred way to connect. The extension cables are configured as follows:</p> <p>USA/Canada: IEC C13 female trailing socket to standard US 3-pin plug</p> <p>UK: IEC C13 female trailing socket to standard UK 3-pin plug</p> <p>Europe: IEC C13 female trailing socket to Schuko 3-pin plug</p> <p>Custom: IEC C13 female trailing socket to any user-specified 3-pin plug</p>
Grounding/Earthing:	<p>All equipment installed within a Kell Systems PSE12 should have conventional grounding/earthing via power cables, but unlike conventional metal-case cabinets, the PSE12 itself has no requirement for additional grounding/earthing in the form of ground strapping or pipe earthing etc. The cabinet shell is constructed entirely from non-conductive materials and the rack is completely isolated from outside contact.</p>
Anti-static measures:	<p>No anti-static measures are required in a PSE12 installation. The rack has full electrical isolation and is not susceptible to static build up that can originate in conventional metal racks by contact with artificial carpet or other flooring materials.</p>
Door locking:	<p>Key operated lock <i>Option for high security code-entry lock, part code CEL1</i></p>
Standards compliance:	<p>Electrical systems meet or exceed BS EN 60950:2000, BS 5733:1995 and ISO 9001-2000 and are compliant ROHS Directive 2002/95 and UL60950-1 (USA).</p> <p>Electronic subsystems meet or exceed EN 60950-1:2006 'Information Technology Equipment – Safety, Part1: General Requirements' and EN292: Part 1: 1991 'Safety of machinery -basic concepts, general principles for design'. Electronics subsystems are CE- certified, certificate number FTE4412GFM-M00 CE, and are compliant with harmonized international standards IEC60950-1:2001 and UL60950-1 (USA).</p> <p>Acoustic foams meet or exceed UL94-HF1 'Standard for Tests for Flammability of Plastic Materials for Parts in Devices and Appliances', (USA) and acoustic barrier materials meet UL94-V0 (USA). Multi-layer composite acoustic materials meet UL94-V0 (USA) and UL94-V2 (USA). Flammability ratings meet or exceed requirements in BS 60950-1:2002 'Information Technology Equipment - Safety' and harmonized international equivalent standards EN60950-1:2001 and IEC60950-1:2001.</p>
Delivery:	<p>All PSE12 are designed to pass through a standard-size doorframe and are normally delivered fully assembled and ready to use. PSE12 can be broken down into component parts where access conditions are constrained. Please consult your Kell Systems representative for details of delivery options in your area.</p>
Warranty:	<p>1 year general warranty against defective workmanship, inclusive of parts and labor 3 years warranty on fan systems up to and inclusive of free replacement</p>

Standard Features and General Specifications

Model PSE18

Air-cooled acoustic server rack enclosure v7.8

PSE18 page 1 of 3

Kell Systems ComputerVault Pro enable deployment of servers and network hardware directly in the office workspace, doing away with the need for dedicated computer rooms. They combine extreme noise reduction and very high thermal capacity with exceptional reliability and a truly all-inclusive, plug-and-play specification. A host of unique, installer-friendly features ensure quick and easy systems deployment and their office-quality appearance blends seamlessly into almost any office environment.

Physical capacity:	18 rack spaces
Noise reduction:	18.5 dB
Max. recommended thermal load:	1.2 kW (4,100 BTU / hr)
Integrated power distribution:	7 x surge-protected outlets
Power consumption:	19 Watts

Please note that standard Kell Systems ComputerVault Pro as shown herein are not suitable for use with blade servers. Please contact your Kell representative about alternative Kell solutions for deployment of these types of devices.

Pictured here in Kell Systems Light Oak effect laminate finish. A wide range of laminate and real wood finishes are available.

Kell laminate-finish ComputerVault Pro have doors and tops that are easy for the user to interchange, so if a unit needs to be relocated to a different office, the look of the cabinet can easily be updated.



Kell Systems Model PSE18 air-cooled acoustic server rack enclosure v7.8

Please note: international product code suffixes are UK, EU (Europe), US (United States & Canada) or CS (custom)

PSE18 page 2 of 3

Standard Features and General Specifications

External dimensions:	Height 1015 mm / 40.4" x Width 750 mm / 29.5" x Depth 1130 mm / 44.5"
Weight:	138 kg / 304 lbs
Physical rack capacity:	18 x EIA 1 $\frac{3}{4}$ " / 44.5 mm rack spaces 4-post rack, fully EIA-compliant, with fixed rear posts and adjustable front posts Rack depth 800 mm / 31.5", adjustable down to 720 mm / 28.3" <i>(option for baying kit to link cabinets together, part code BK18)</i>
Extra internal cabinet depth:	Forward of the front rack posts: 100 mm / 4" space for front frame cabling/patching <i>(see product guide page 19, figure "Kell Systems ComputerVault Pro plan section")</i> Rearward of the rear rack posts: 60 mm / 2" except where fan modules intrude <i>(see product guide page 18, figure "Kell Systems ComputerVault Pro side sections")</i>
Floor space requirements:	Individual cabinets are designed to be pushed back flush against a wall. An air space of 200 mm / 8" on both sides of the cabinet is essential for normal operation.
Baying cabinets together:	Baying kit option available. The easy-to-fit baying kit maintains the soundproof seal but opens adjacent cabinets onto each other internally. Special notes on baying: 1: Unlike single cabinets, bayed cabinets cannot be pushed fully back against a wall. Air space of 100 mm / 6" behind the cabinet is essential for normal operation. 2: Baying PSE18 cabinets together reduces the maximum recommended thermal load in each cabinet from 1.2 kW to 1 kW. 3: In bayed cabinets, it is essential that the thermal load is distributed evenly between the cabinets.
Cooling system:	1 x Kell Systems ultra-low-noise exhaust fan module 1.2 kW maximum recommended total thermal load (or 4,100 BTU / hr)
Power consumption:	19 Watts total power consumption by the PSE18 itself, including cooling system
Noise of PSE18 itself:	40.5 dBA total noise generated by unit, measured 1.0 m / 39" in front of the cabinet
Noise reduction:	18.5 dB broadband noise reduction, measured 1.0 m / 39" in front of the cabinet <i>(HP and Dell servers used as noise source in noise reduction measurements)</i>
Mobility:	4 x heavy duty castor-type wheels Front wheels have 360° rotation for steerability Rear wheels have fixed front-to-back motion for stability
Rear and side access:	Detachable rear side panels, left and right, for installation and maintenance access Detachable rear fan module backplane gives completely open rear rack access
Cable management:	70mm / 2.75" width full-height vertical cable trays to each side of front of rack 70mm / 2.75" width full-height vertical cable trays to each side of middle of rack 70mm / 2.75" width full-height vertical cable trays to each side of rear of rack <i>(see product guide page 19, figure "Kell Systems ComputerVault Pro plan section")</i> Option for heavy duty cable management ladders to front of rack for larger scale network cabling applications, part code VCM18
Dust filtering:	Optional air intake dust filters, part code DF18

Kell Systems Model PSE18 air-cooled acoustic server rack enclosure v7.8

Please note: international product code suffixes are UK, EU (Europe), US (United States & Canada) or CS (custom)

PSE18 page 3 of 3

Standard Features and General Specifications (continued)

Internal power distribution:	<p>All power outlets in Kell Systems PSE18 feature surge protection</p> <p>USA/Canada: 7 x US 3 pin sockets, arranged vertically</p> <p>UK & Europe: 7 x IEC 320 C13 (10 A / 220/240 V) sockets, arranged vertically</p> <p>Rest of world: 7 x IEC 320 C13, arranged vertically, unless specified otherwise</p>
Power input connection:	<p>All PSE18 have power input via an IEC 320 C14 (male) trailing lead for connection to an in-rack UPS, and an extension cable for connection to a wall outlet. User may choose the preferred way to connect. The extension cables are configured as follows:</p> <p>USA/Canada: IEC C13 female trailing socket to standard US 3-pin plug</p> <p>UK: IEC C13 female trailing socket to standard UK 3-pin plug</p> <p>Europe: IEC C13 female trailing socket to Schuko 3-pin plug</p> <p>Custom: IEC C13 female trailing socket to any user-specified 3-pin plug</p>
Grounding/Earthing:	<p>All equipment installed within a Kell Systems PSE18 should have conventional grounding/earthing via power cables, but unlike conventional metal-case cabinets, the PSE18 itself has no requirement for additional grounding/earthing in the form of ground strapping or pipe earthing etc. The cabinet shell is constructed entirely from non-conductive materials and the rack is completely isolated from outside contact.</p>
Anti-static measures:	<p>No anti-static measures are required in a PSE18 installation. The rack has full electrical isolation and is not susceptible to static build up that can originate in conventional metal racks by contact with artificial carpet or other flooring materials.</p>
Door locking:	<p>Key operated lock <i>Option for high security code-entry lock, part code CEL1</i></p>
Standards compliance:	<p>Electrical systems meet or exceed BS EN 60950:2000, BS 5733:1995 and ISO 9001-2000 and are compliant ROHS Directive 2002/95 and UL60950-1 (USA).</p> <p>Electronic subsystems meet or exceed EN 60950-1:2006 'Information Technology Equipment – Safety, Part1: General Requirements' and EN292: Part 1: 1991 'Safety of machinery -basic concepts, general principles for design'. Electronics subsystems are CE- certified, certificate number FTE4412GFM-M00 CE, and are compliant with harmonized international standards IEC60950-1:2001 and UL60950-1 (USA).</p> <p>Acoustic foams meet or exceed UL94-HF1 'Standard for Tests for Flammability of Plastic Materials for Parts in Devices and Appliances', (USA) and acoustic barrier materials meet UL94-V0 (USA). Multi-layer composite acoustic materials meet UL94-V0 (USA) and UL94-V2 (USA). Flammability ratings meet or exceed requirements in BS 60950-1:2002 'Information Technology Equipment - Safety' and harmonized international equivalent standards EN60950-1:2001 and IEC60950-1:2001.</p>
Delivery:	<p>All Kell Systems PSE18 are designed to pass through a standard-size doorframe and are normally delivered fully assembled and ready to use. PSE18 can be broken down into component parts where access conditions are constrained. Please consult your Kell Systems representative for details of delivery options in your area.</p>
Warranty:	<p>1 year general warranty against defective workmanship, inclusive of parts and labor 3 years warranty on fan systems up to and inclusive of free replacement</p>

Standard Features and General Specifications

Model PSE24

Air-cooled acoustic server rack enclosure v7.8

PSE24 page 1 of 3

Kell Systems ComputerVault Pro enable deployment of servers and network hardware directly in the office workspace, doing away with the need for dedicated computer rooms. They combine extreme noise reduction and very high thermal capacity with exceptional reliability and a truly all-inclusive, plug-and-play specification. A host of unique, installer-friendly features ensure quick and easy systems deployment and their office-quality appearance blends seamlessly into almost any office environment.

Physical capacity:	24 rack spaces
Noise reduction:	18.5 dB
Max. recommended thermal load:	2.4 kW (8,200 BTU / hr)
Integrated power distribution:	10 x surge-protected outlets
Power consumption:	38 Watts

Please note that standard Kell Systems ComputerVault Pro as shown herein are not suitable for use with blade servers. Please contact your Kell representative about alternative Kell solutions for deployment of these types of devices.

Pictured here in Kell Systems Light Oak effect laminate finish. A wide range of laminate and real wood finishes are available.

Kell laminate-finish ComputerVault Pro have doors and tops that are easy for the user to interchange, so if a unit needs to be relocated to a different office, the look of the cabinet can easily be updated.



Kell Systems Model PSE24 air-cooled acoustic server rack enclosure v7.8

Please note: international product code suffixes are UK, EU (Europe), US (United States & Canada) or CS (custom)

PSE24 page 2 of 3

Standard Features and General Specifications

External dimensions:	Height 1285 mm / 50.6" x Width 750 mm / 29.5" x Depth 1130 mm / 44.5"
Weight:	169.5 kg / 373 lbs
Physical rack capacity:	24 x EIA 1 $\frac{3}{4}$ " / 44.5 mm rack spaces 4-post rack, fully EIA-compliant, with fixed rear posts and adjustable front posts Rack depth 800 mm / 31.5", adjustable down to 720 mm / 28.3" (option for baying kit to link cabinets together, part code BK24)
Extra internal cabinet depth:	Forward of the front rack posts: 100 mm / 4" space for front frame cabling/patching (see product guide page 19, figure "Kell Systems ComputerVault Pro plan section") Rearward of the rear rack posts: 60 mm / 2" except where fan modules intrude (see product guide page 18, figure "Kell Systems ComputerVault Pro side sections")
Floor space requirements:	Individual cabinets are designed to be pushed back flush against a wall. An air space of 200 mm / 8" on both sides of the cabinet is essential for normal operation.
Baying cabinets together:	Baying kit option available. The easy-to-fit baying kit maintains the soundproof seal but opens adjacent cabinets onto each other internally. Special notes on baying: 1: Unlike single cabinets, bayed cabinets cannot be pushed fully back against a wall. Air space of 100 mm / 6" behind the cabinet is essential for normal operation. 2: Baying PSE24 cabinets together reduces the maximum recommended thermal load in each cabinet from 2.4 kW to 2.0 kW. 3: In bayed cabinets, it is essential that the thermal load is distributed evenly between the cabinets.
Cooling system:	2 x Kell Systems ultra-low-noise exhaust fan modules 2.4 kW maximum recommended total thermal load (or 8,200 BTU / hr)
Power consumption:	38 Watts total power consumption by the PSE24 itself, including cooling system
Noise of PSE24 itself:	43.0 dBA total noise generated by unit, measured 1.0 m / 39" in front of the cabinet
Noise reduction:	18.5 dB broadband noise reduction, measured 1.0 m / 39" in front of the cabinet (HP and Dell servers used as noise source in noise reduction measurements)
Mobility:	4 x heavy duty castor-type wheels Front wheels have 360° rotation for steerability Rear wheels have fixed front-to-back motion for stability
Rear and side access:	Detachable rear side panels, left and right, for installation and maintenance access Detachable rear fan module backplane gives completely open rear rack access
Cable management:	70mm / 2.75" width full-height vertical cable trays to each side of front of rack 70mm / 2.75" width full-height vertical cable trays to each side of middle of rack 70mm / 2.75" width full-height vertical cable trays to each side of rear of rack (see product guide page 19, figure "Kell Systems ComputerVault Pro plan section") Option for heavy duty cable management ladders to front of rack for larger-scale network cabling applications, part code VCM24
Dust filtering:	Optional air intake dust filters, part code DF24

Kell Systems Model PSE24 air-cooled acoustic server rack enclosure v7.8

Please note: international product code suffixes are UK, EU (Europe), US (United States & Canada) or CS (custom)

PSE24 page 3 of 3

Standard Features and General Specifications (continued)

Internal power distribution:	<p>All power outlets in Kell Systems PSE24 feature surge protection</p> <p>USA/Canada: 10 x US 3 pin sockets, arranged vertically</p> <p>UK & Europe: 10 x IEC 320 C13 (10 A / 220/240 V) sockets, arranged vertically</p> <p>Rest of world: 10 x IEC 320 C13, arranged vertically, unless specified otherwise</p>
Power input connection:	<p>All PSE24 have power input via an IEC 320 C14 (male) trailing lead for connection to an in-rack UPS, and an extension cable for connection to a wall outlet. User may choose the preferred way to connect. The extension cables are configured as follows:</p> <p>USA/Canada: IEC C13 female trailing socket to standard US 3-pin plug</p> <p>UK: IEC C13 female trailing socket to standard UK 3-pin plug</p> <p>Europe: IEC C13 female trailing socket to Schuko 3-pin plug</p> <p>Custom: IEC C13 female trailing socket to any user-specified 3-pin plug</p>
Grounding/Earthing:	<p>All equipment installed within a Kell Systems PSE24 should have conventional grounding/earthing via power cables, but unlike conventional metal-case cabinets, the PSE24 itself has no requirement for additional grounding/earthing in the form of ground strapping or pipe earthing etc. The cabinet shell is constructed entirely from non-conductive materials and the rack is completely isolated from outside contact.</p>
Anti-static measures:	<p>No anti-static measures are required in a PSE24 installation. The rack has full electrical isolation and is not susceptible to static build up that can originate in conventional metal racks by contact with artificial carpet or other flooring materials.</p>
Door locking:	<p>Key operated lock <i>Option for high security code-entry lock, part code CEL1</i></p>
Standards compliance:	<p>Electrical systems meet or exceed BS EN 60950:2000, BS 5733:1995 and ISO 9001-2000 and are compliant ROHS Directive 2002/95 and UL60950-1 (USA).</p> <p>Electronic subsystems meet or exceed EN 60950-1:2006 'Information Technology Equipment – Safety, Part1: General Requirements' and EN292: Part 1: 1991 'Safety of machinery -basic concepts, general principles for design'. Electronics subsystems are CE- certified, certificate number FTE4412GFM-M00 CE, and are compliant with harmonized international standards IEC60950-1:2001 and UL60950-1 (USA).</p> <p>Acoustic foams meet or exceed UL94-HF1 'Standard for Tests for Flammability of Plastic Materials for Parts in Devices and Appliances', (USA) and acoustic barrier materials meet UL94-V0 (USA). Multi-layer composite acoustic materials meet UL94-V0 (USA) and UL94-V2 (USA). Flammability ratings meet or exceed requirements in BS 60950-1:2002 'Information Technology Equipment - Safety' and harmonized international equivalent standards EN60950-1:2001 and IEC60950-1:2001.</p>
Delivery:	<p>All PSE24 are designed to pass through a standard-size doorframe and are normally delivered fully assembled and ready to use. PSE24 can be broken down into component parts where access conditions are constrained. Please consult your Kell Systems representative for details of delivery options in your area.</p>
Warranty:	<p>1 year general warranty against defective workmanship, inclusive of parts and labor 3 years warranty on fan systems up to and inclusive of free replacement</p>

Standard Features and General Specifications

Model PSE38

Air-cooled acoustic server rack enclosure v7.8

PSE38 page 1 of 3

Kell Systems ComputerVault Pro enable deployment of servers and network hardware directly in the office workspace, doing away with the need for dedicated computer rooms. They combine extreme noise reduction and very high thermal capacity with exceptional reliability and a truly all-inclusive, plug-and-play specification. A host of unique, installer-friendly features ensure quick and easy systems deployment and their office-quality appearance blends seamlessly into almost any office environment.

Physical capacity:	38 rack spaces
Noise reduction:	18.5 dB
Max. recommended thermal load:	3.6 kW (12,300 BTU / hr)
Integrated power distribution:	13 x surge-protected outlets
Power consumption:	57 Watts

Please note that standard Kell Systems ComputerVault Pro as shown herein are not suitable for use with blade servers. Please contact your Kell representative about alternative Kell solutions for deployment of these types of devices.

Pictured here in Kell Systems Light Oak effect laminate finish. A wide range of laminate and real wood finishes are available.

Kell laminate-finish ComputerVault Pro have doors and tops that are easy for the user to interchange, so if a unit needs to be relocated to a different office, the look of the cabinet can easily be updated.



Kell Systems Model PSE38 air-cooled acoustic server rack enclosure v7.8

Please note: international product code suffixes are UK, EU (Europe), US (United States & Canada) or CS (custom)

PSE38 page 2 of 3

Standard Features and General Specifications

External dimensions:	Height 1950 mm / 76.7" x Width 750 mm / 29.5" x Depth 1130 mm / 44.5"
Weight:	199.5 kg / 434 lbs
Physical rack capacity:	38 x EIA 1 $\frac{3}{4}$ " / 44.5 mm rack spaces 4-post rack, fully EIA-compliant, with fixed rear posts and adjustable front posts Rack depth 800 mm / 31.5", adjustable down to 720 mm / 28.3" <i>(option for baying kit to link cabinets together, part code BK38)</i>
Extra internal cabinet depth:	Forward of the front rack posts: 100 mm / 4" space for front frame cabling/patching <i>(see product guide page 19, figure "Kell Systems ComputerVault Pro plan section")</i> Rearward of the rear rack posts: 60 mm / 2" except where fan modules intrude <i>(see product guide page 18, figure "Kell Systems ComputerVault Pro side sections")</i>
Floor space requirements:	Individual cabinets are designed to be pushed back flush against a wall. An air space of 200 mm / 8" on both sides of the cabinet is essential for normal operation.
Baying cabinets together:	Baying kit option available. The easy-to-fit baying kit maintains the soundproof seal but opens adjacent cabinets onto each other internally. Special notes on baying: 1: Unlike single cabinets, bayed cabinets cannot be pushed fully back against a wall. Air space of 100 mm / 6" behind the cabinet is essential for normal operation. 2: Baying PSE38 cabinets together reduces the maximum recommended thermal load in each cabinet from 3.6 kW to 3.0 kW. 3: In bayed cabinets, it is essential that the thermal load is distributed evenly between the cabinets.
Cooling system:	3 x Kell Systems ultra-low-noise exhaust fan modules 3.6 kW maximum recommended total thermal load (or 12,300 BTU / hr)
Power consumption:	57 Watts total power consumption by the PSE38 itself, including cooling system
Noise of PSE38 itself:	43.5 dBA total noise generated by unit, measured 1.0 m / 39" in front of the cabinet
Noise reduction:	18.5 dB broadband noise reduction, measured 1.0 m / 39" in front of the cabinet <i>(HP and Dell servers used as noise source in noise reduction measurements)</i>
Mobility:	4 x heavy duty castor-type wheels Front wheels have 360° rotation for steerability Rear wheels have fixed front-to-back motion for stability
Rear and side access:	Detachable rear side panels, left and right, for installation and maintenance access Detachable rear fan module backplane gives completely open rear rack access
Cable management:	70mm / 2.75" width full-height vertical cable trays to each side of front of rack 70mm / 2.75" width full-height vertical cable trays to each side of middle of rack 70mm / 2.75" width full-height vertical cable trays to each side of rear of rack <i>(see product guide page 19, figure "Kell Systems ComputerVault Pro plan section")</i> Option for heavy duty cable management ladders to front of rack for larger scale network cabling applications, part code VCM38
Dust filtering:	Optional air intake dust filters, part code DF38

Kell Systems Model PSE38 air-cooled acoustic server rack enclosure v7.8

Please note: international product code suffixes are UK, EU (Europe), US (United States & Canada) or CS (custom)

PSE38 page 3 of 3

Standard Features and General Specifications (continued)

Internal power distribution:	<p>All power outlets in Kell Systems PSE38 feature surge protection</p> <p>USA/Canada: 13 x US 3 pin sockets, arranged vertically</p> <p>UK & Europe: 13 x IEC 320 C13 (10 A / 220/240 V) sockets, arranged vertically</p> <p>Rest of world: 13 x IEC 320 C13, arranged vertically, unless specified otherwise</p>
Power input connection:	<p>All PSE38 have power input via an IEC 320 C14 (male) trailing lead for connection to an in-rack UPS, and an extension cable for connection to a wall outlet. User may choose the preferred way to connect. The extension cables are configured as follows:</p> <p>USA/Canada: IEC C13 female trailing socket to standard US 3-pin plug</p> <p>UK: IEC C13 female trailing socket to standard UK 3-pin plug</p> <p>Europe: IEC C13 female trailing socket to Schuko 3-pin plug</p> <p>Custom: IEC C13 female trailing socket to any user-specified 3-pin plug</p>
Grounding/Earthing:	<p>All equipment installed within a Kell Systems PSE38 should have conventional grounding/earthing via power cables, but unlike conventional metal-case cabinets, the PSE38 itself has no requirement for additional grounding/earthing in the form of ground strapping or pipe earthing etc. The cabinet shell is constructed entirely from non-conductive materials and the rack is completely isolated from outside contact.</p>
Anti-static measures: has	<p>No anti-static measures are required in a Kell Systems PSE38 installation. The rack full electrical isolation and is not susceptible to static build up that can originate in conventional metal racks by contact with artificial carpet or other flooring materials.</p>
Door locking:	<p>Key operated lock <i>Option for high security code-entry lock, part code CEL1</i></p>
Standards compliance:	<p>Electrical systems meet or exceed BS EN 60950:2000, BS 5733:1995 and ISO 9001-2000 and are compliant ROHS Directive 2002/95 and UL60950-1 (USA).</p> <p>Electronic subsystems meet or exceed EN 60950-1:2006 'Information Technology Equipment – Safety, Part1: General Requirements' and EN292: Part 1: 1991 'Safety of machinery -basic concepts, general principles for design'. Electronics subsystems are CE- certified, certificate number FTE4412GFM-M00 CE, and are compliant with harmonized international standards IEC60950-1:2001 and UL60950-1 (USA).</p> <p>Acoustic foams meet or exceed UL94-HF1 'Standard for Tests for Flammability of Plastic Materials for Parts in Devices and Appliances', (USA) and acoustic barrier materials meet UL94-V0 (USA). Multi-layer composite acoustic materials meet UL94-V0 (USA) and UL94-V2 (USA). Flammability ratings meet or exceed requirements in BS 60950-1:2002 'Information Technology Equipment - Safety' and harmonized international equivalent standards EN60950-1:2001 and IEC60950-1:2001.</p>
Delivery:	<p>All PSE38 are designed to pass through a standard-size doorframe and are normally delivered fully assembled and ready to use. PSE38 can be broken down into component parts where access conditions are constrained. Please consult your Kell Systems representative for details of delivery options in your area.</p>
Warranty:	<p>1 year general warranty against defective workmanship, inclusive of parts and labor 3 years warranty on fan systems up to and inclusive of free replacement</p>

Kell Systems ComputerVault Pro air-cooled acoustic server rack enclosures

Noise reduction performance

Server noise attenuation: 18.5 dBA broadband noise reduction, measured 1.0 m / 39" in front of the cabinet
(Representing the elimination of 98.5% of server noise)

Practical explanation:

The field of acoustics is not an area familiar to many IT managers and therefore the following guidelines are offered.

"dBA" is the common measurement unit used to quantify Sound Pressure Level (SPL), which is technical terminology for "how loud things are". As usual with these things, there's no need for the end user to fully understand dBA. The things that matter are how many or how few of them there are, and what that means in the real world. For reference, here are some widely-accepted examples of SPL ratings that are relevant when installing servers in the workplace:

- 50 dBA Background noise in an average office, without speech
- 55 dBA Background noise in a busy office, without speech
- 60 dBA Normal conversational speech

- 45 to 50 dBA Typical noise from fully integrated or cassette-type building air conditioning
- 55 dBA + Typical noise from portable air conditioners

- 62 dBA Typical noise from 2 x low form factor servers with average CPU loads
- 65 dBA Typical noise from 4 x low form factor servers with average CPU loads
- 68 dBA Typical noise from 8 x low form factor servers with average CPU loads
(every doubling of the number of servers leads to a 3 dBA increase in the total noise level)

In order for an installation to become unobtrusive in an office environment, the noise from the servers and other hardware in the installation must be reduced to the level of the general office background noise. At such reduced levels, the human brain perceives the noise from the servers as part of the overall background noise, and it will go unnoticed on a day-to-day basis, in much the same way that the hum from most built-in office air conditioning systems do.

The following tables give a guide to how this is achieved by the use of Kell Systems ComputerVault Pro enclosures.

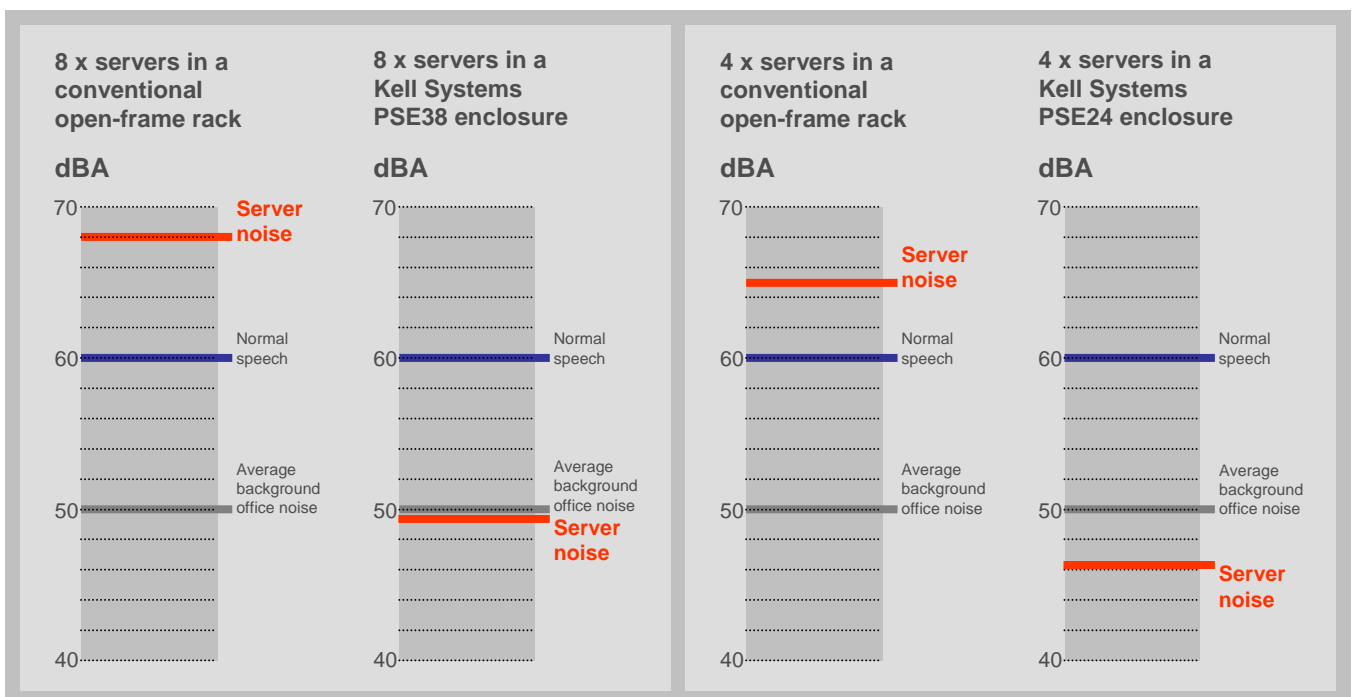

Kell Systems ComputerVault Pro air-cooled acoustic server rack enclosures

Thermal performance of Kell Systems ComputerVault Pro

The effect to server operating conditions, provided that Kell Systems thermal loading and installation guidelines are adhered to, is so slight as to be insignificant.

To understand how effective the ComputerVault Pro's thermal management system is, please consider the following example of a Kell v7.8 PSE18 enclosure's impact to server CPU temperatures, under normal "office" environmental conditions, compared to operation of those same servers in free space.

Test conditions:

Equipment used:

Kell Unit: Model PSE18 v7.8, maximum recommended thermal load 1.2 kW

Server 1: HP Proliant DL380 G4 2U rack-mount server with 2 x 3.2 GHz Intel Xeon processors

Server 2: HP Proliant DL380 G4 2U rack-mount server with 2 x 3.2 GHz Intel Xeon processors

Server 3: HP Proliant ML370 G4 5U rack-converted server with 2 x 3.2 Intel Xeon GHz processors

Incidental hardware also present in PSE18 during example test:

APC Smart-UPS 3000 VA 3U rack-mount UPS

3 x Netgear network switches

2 x 1U climate monitoring devices

Test and measurement method

CPU temperature measurements were taken using HP Systems Insight Manager software

Continuous CPU loads were generated using BurnInTest software by Passmark

Room ambient temperature measurements were taken by recording the average reading of 2 x digital thermometers

Room ambient air temperature

The test room air temperature was maintained at a constant 24°C / 75°F (+/- 0.5°C) throughout the test period (equivalent to a moderately warm office).

Procedure used in example tests

- 1) In the first instance the entire outer shell of the PSE18 was removed, and the CPU temperatures were recorded at "idle" (running but not processing client tasks) in free air space. Removing the cabinet's casing created thermal conditions identical to those in a conventional open-frame rack, or with servers not rack-mounted but resting on surfaces.
- 2) Identical and continuous processing loads, generated by the test software, were applied to all six CPUs simultaneously, such that utilization in all CPUs was increased in steps from "idle" to 20%, 40%, 60%, 80% and 100%. After each step change in CPU loading, CPU temperatures were allowed to stabilize for one hour, and then the operating temperature of each of the six CPUs was measured/recorded using the server manufacturer's own software.
- 3) The outer shell of the server cabinet was then fully reinstated, and the above test procedure was replicated.

The following results were recorded (please see graphical records on page 16 of this document):

The average increase in CPU temperature attributable to the PSE18, versus free space operation, was +3.2° Celsius

The electrical consumption of the combined systems, with all CPUs at 100% utilization continuously, was 1.076 kW.

Kell Systems ComputerVault Pro air-cooled acoustic server rack enclosures

Thermal capacity (measurements from example scenario detailed on page 15 of this document)

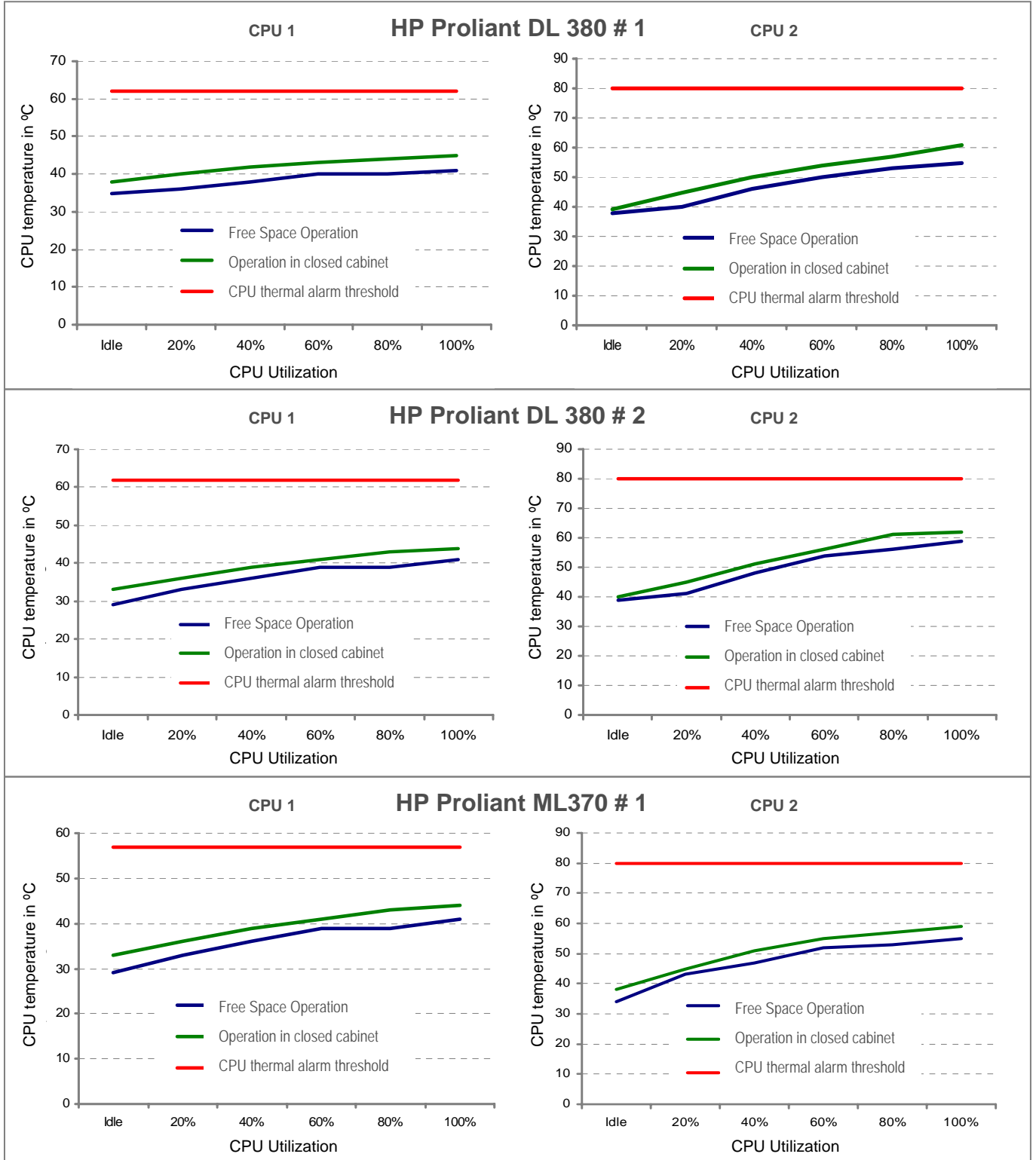

Kell Systems ComputerVault Pro external views

PSE12

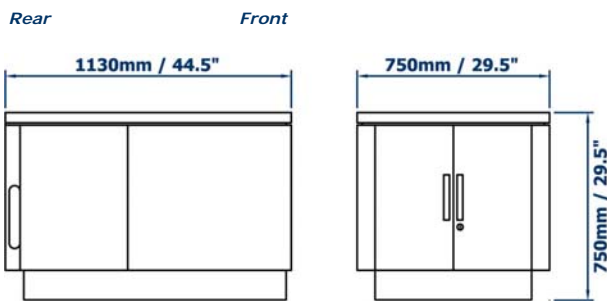

PSE18

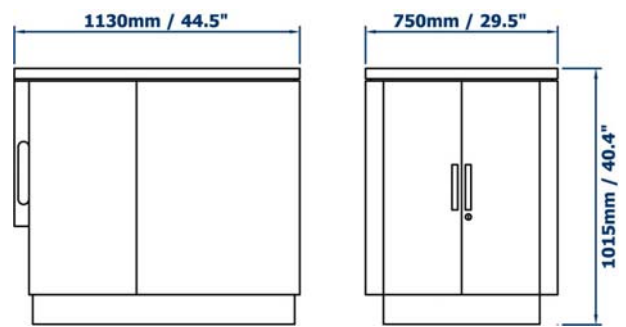

PSE24

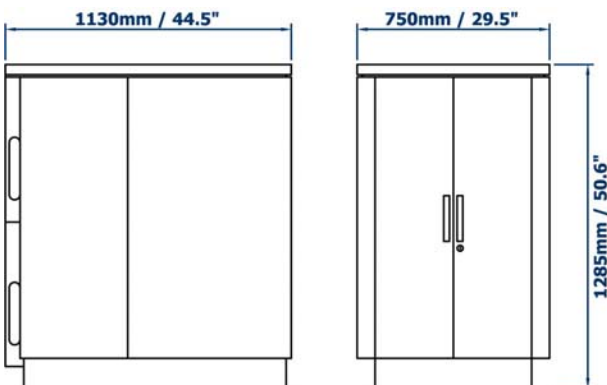

PSE38

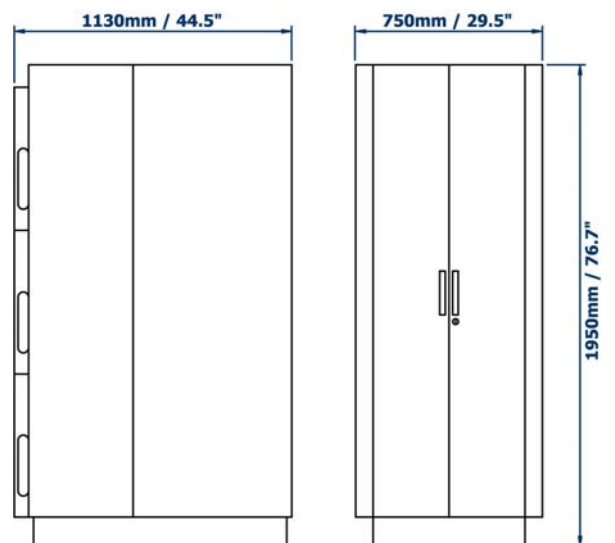

Kell Systems ComputerVault Pro side sections

Please note reduction in internal cabinet depth in some rack units due to triangular protrusion of Kell exhaust fan module. Very deep servers or other such hardware must be installed above or below Kell fan modules.

Dimension key:

- a) 775 mm / 30.5"
- b) 800 mm / 31.5"
- c) 860 mm / 33.5"
- d) 1010 mm / 39.5"

e) Indicates soundproofed cable entry / exit pathway (acoustic materials not shown). The cable port is large enough to accommodate several hundred Ethernet cables and has a removable top cover. The design is such that pre-terminated patch panels can be installed effortlessly, with no need for de-termination and re-termination. The model PSE38 has an option for a second such cable port in the top of the cabinet, for use where cables run in ceilings.

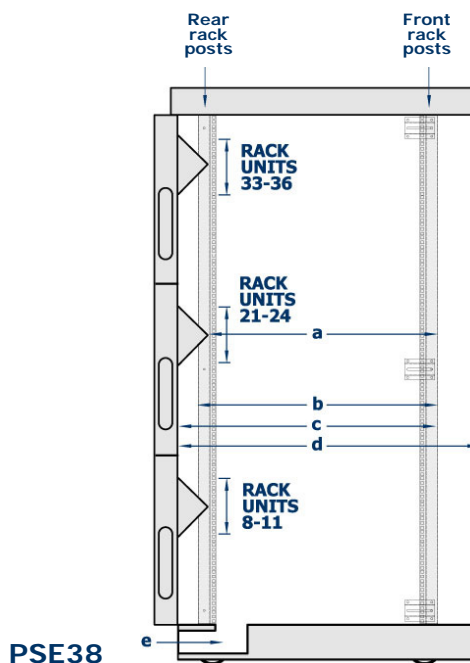
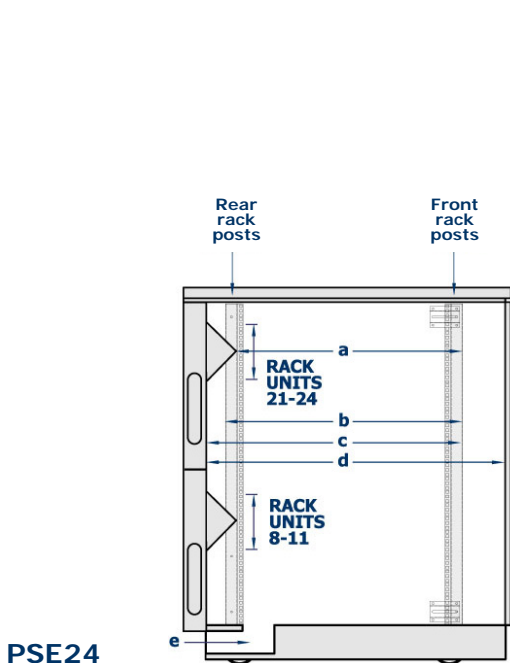
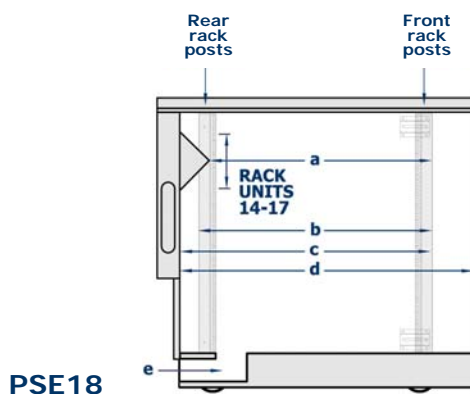
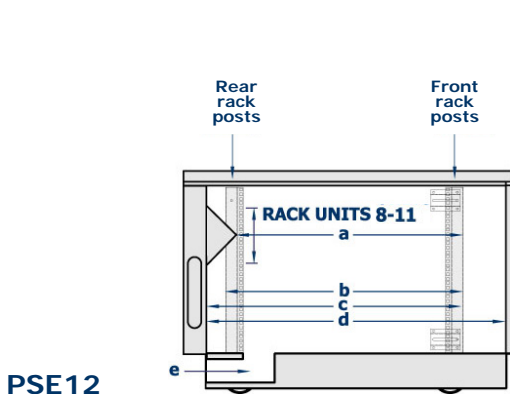

Kell Systems ComputerVault Pro plan section, common to all ComputerVault Pro

 Air paths

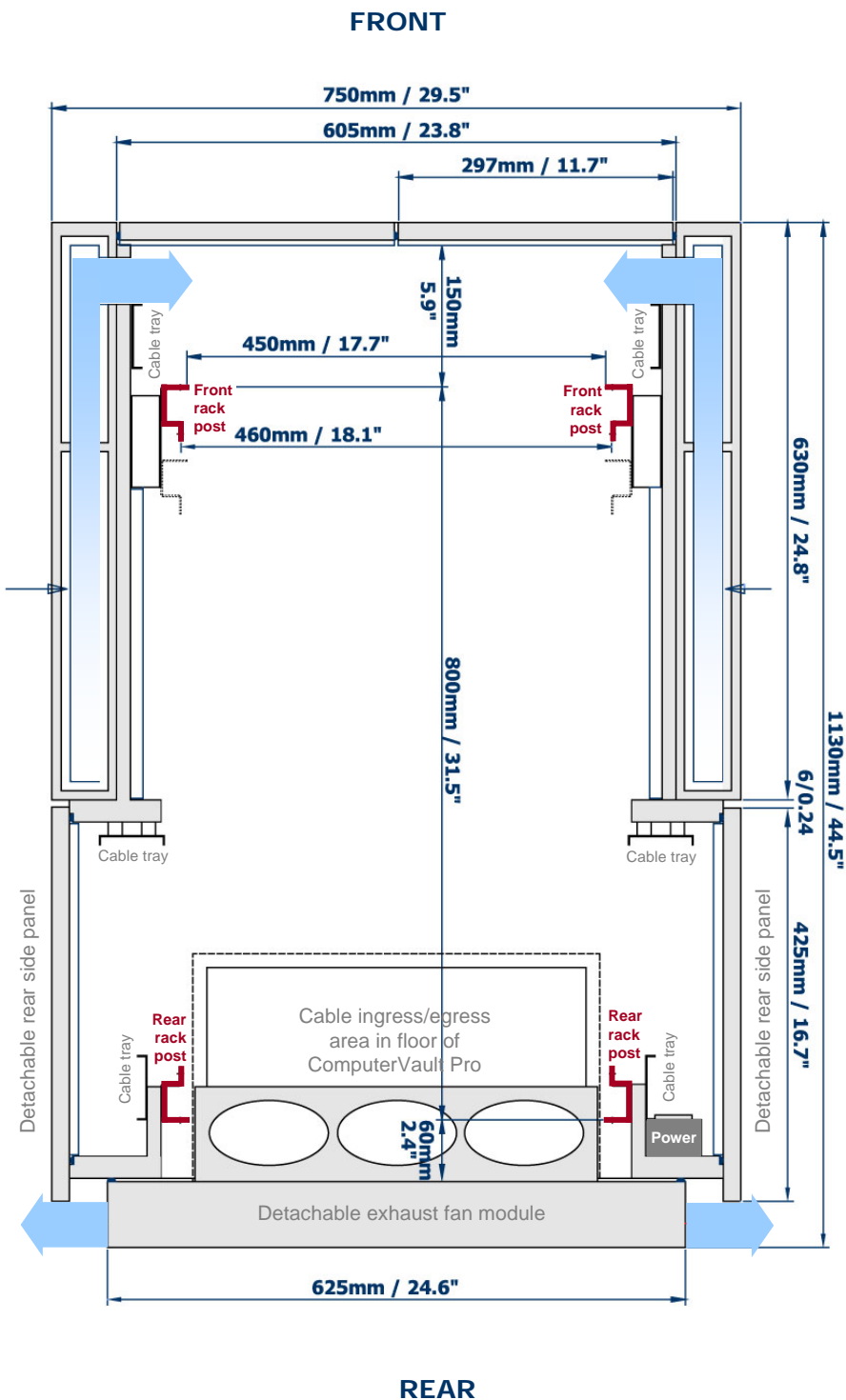

Kell Systems ComputerVault Pro rack planning guidelines

Please note the following guidelines for best installation and operation of hardware in a Kell ComputerVault Pro. Specific cabinet sizes are shown for illustration purposes below, but the principles extend to all ComputerVault Pro sizes.

Figure 1: distribution of thermal load

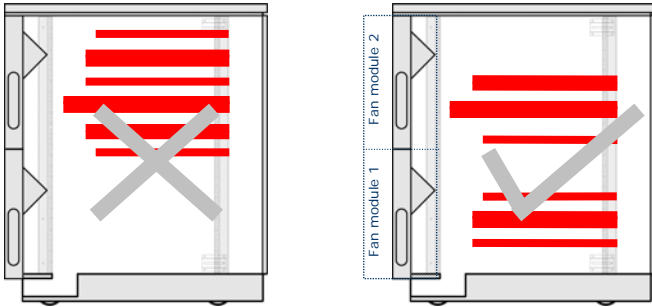

Avoid clustering **hot-running devices** such as servers, dense RAID arrays and large VoIP switches in one part of the rack. Distribute the thermal load evenly up and down the rack such that each Kell fan module supports an equal amount of the thermal load, or as close to it as possible. The cabinet shown in this example is the model PSE24, which has 2 x fan modules. Models PSE12 and PSE18 each have 1 x fan module, and model PSE38 has 3 x fan modules.

Figure 2: selecting the best location for very deep servers

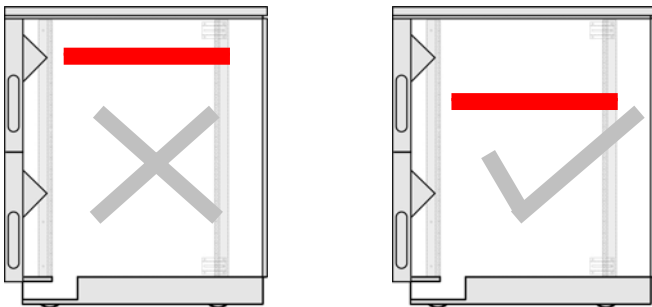

Each fan module has a triangular metal section protruding slightly into the cabinet (please also see side section drawings on page 17 of this document). This does not create an issue for installation of most equipment, but to allow for ample cabling space to the rear, deep servers are generally best installed in the rack spaces above and below these triangular metal protrusions.

Figure 3: baying cabinets together

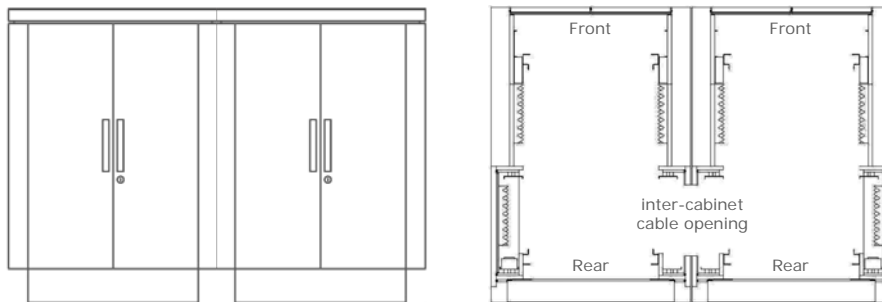

When the optional baying kit is used to link units together, the rear sections of the cabinets are open to each other as shown here.

Figure 4: distribution of thermal load in bayed cabinets

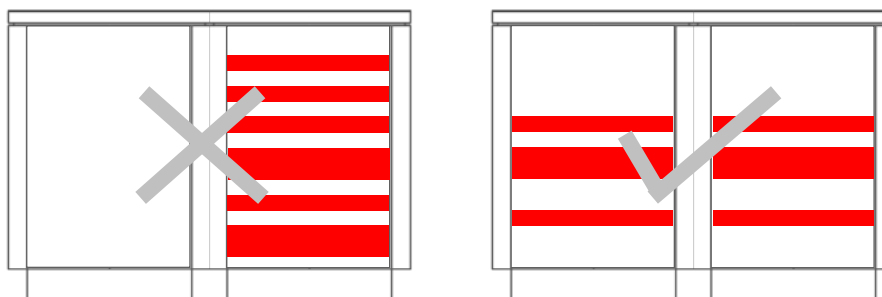

When installing hardware in bayed units, distribute **hot-running devices** evenly between the cabinets as shown. Also see notes in figure 1 above.

About Kell Systems

Kell Systems has pioneered the design and manufacture of Portable Server Environments (PSEs), the first complete solution for deployment of servers and network hardware directly in the office workplace. Kell PSEs are an award-winning new concept and a very real, self-contained alternative to building computer rooms. Kell PSEs are exported throughout the world and are installed in locations from Bali to Bratislava and from Hawaii to Hong Kong.

Kell Systems Ltd. is a privately-held English company founded in 2003, headquartered in Marlow, Buckinghamshire, with its manufacturing and distribution facility in Frome, Somerset.

Kell Systems Inc. is a subsidiary company of Kell Systems Ltd, with offices and showrooms in Chantilly, Virginia (Washington D.C. area). Kell Systems Inc. warehouses inventory and manages its own distribution operations in the USA.

Kell Systems (Vertrieb Deutschland) is Kell Systems' sales office in Germany and Kell Systems (Ventas España) is Kell Systems' sales office in Spain.

Kell Systems Inc, USA.
14141 Robert Paris Ct.
Chantilly
VA 20151, USA
T :: +1 703 818 0033
Email:: info@kellsystems.com
Web:: www.kellsystems.com

Kell Systems Vertrieb Deutschland

T :: +49 30 303 661 988
Email :: info@kellsystems.de
Web :: www.kellsystems.de

Kell Systems Ltd,
Regency House
Mere Park, Dedmere Road
Marlow
Buckinghamshire SL7 1FJ
England
T :: +44 (0) 1628 474757
Email :: info@kellsystems.co.uk
Web :: www.kellsystems.co.uk

Kell Systems Ventas España

T: +34 91 636 2961
Email :: info@kellsystems.es
Web :: www.kellsystems.es

Kell Systems Manufacturing
Ashton Park
Handlemaker Road
Frome
Somerset, BA11 4RW
England
T :: +44 (0) 1373 452 334
Email:: aftersales@kellsystems.co.uk



Kell Systems' Ashton Park manufacturing facility